

# STEPMASTER™ ASSEMBLY INSTRUCTIONS

## 3 SHELF WIDE PYRAMID

Oil all sockets before assembly

**Components**  
SM662403P3  
**Panels**

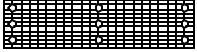

(2) Floor panel (16"x5.5' w/ holes)



(2) Middle panel (16"x5.5')

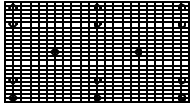

(1) Top panel (3'x5.5')

**Legs:**  
(12) 12"  
(6) 24"

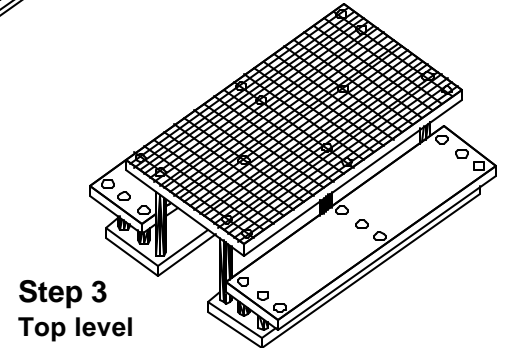
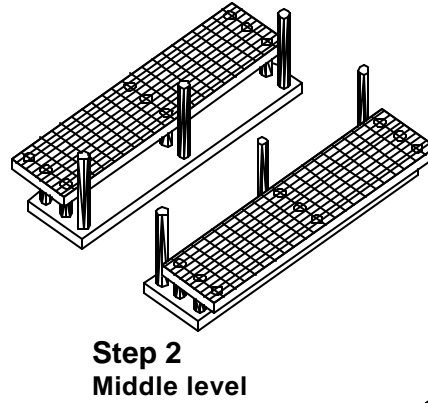
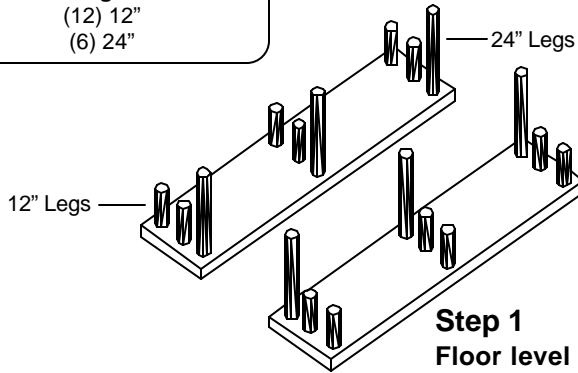

**Components:**  
SM962403P3  
**Panels**



(2) Floor panel (16"x8' w/ holes)



(2) Middle panel (16"x8')

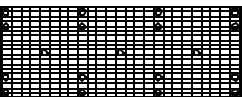

(1) Top panel (3'x8')

**Legs:**  
(16) 12"  
(8) 24"

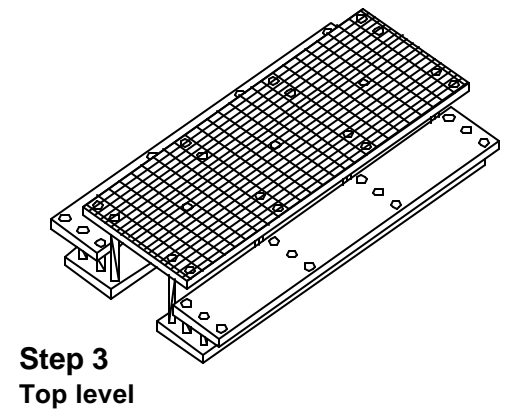
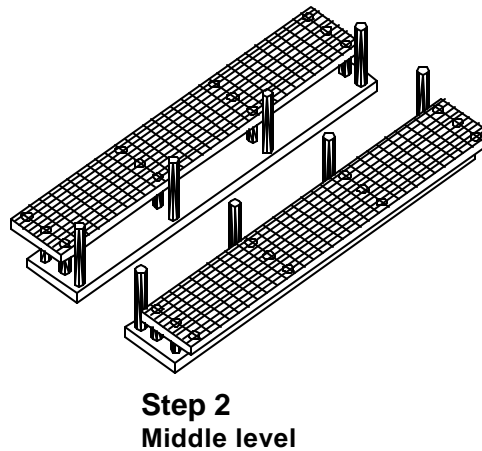
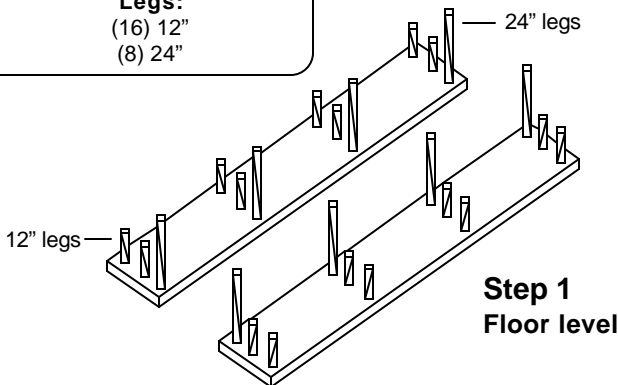

### Step 1

Lay floor panels (**open hole sockets**) in position and place legs as shown. (Make sure legs go through to ground).

### Step 2

Position the (2) **middle panels** (closed hole sockets) on **12" legs** overhanging outside edges as shown. Push down until leg rests on top of socket.

### Step 3

Position the top panel (**closed hole sockets**) on **24" legs** using inside row of sockets as shown. Push down until leg rests on top of socket.