

# ASSEMBLY INSTRUCTIONS

## SM367203WWB



Check All Components

### Components:

#### Panels:

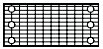

(2) Floor Panels (open hole sockets)

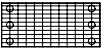

(1) 1st Level (closed hole sockets)

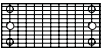

(2) 2nd and 3rd Levels (open center hole sockets)

#### Legs:

- (8) - 12"
- (2) - 24"
- (2) - 36"
- (4) - 72"

#### Waterbeds:

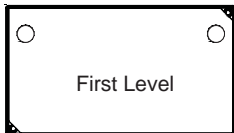

Outside holes

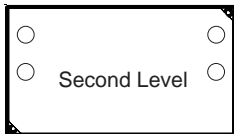

Outside/Center holes



Center holes

Oil All Sockets Before Assembly

### Step 1

#### Floor Level

Place legs as shown. Push legs through to ground.

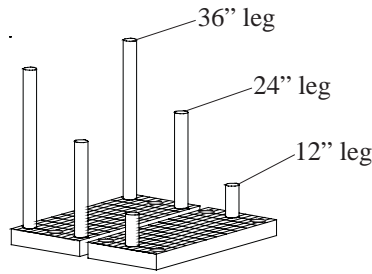

### Fully Assembled

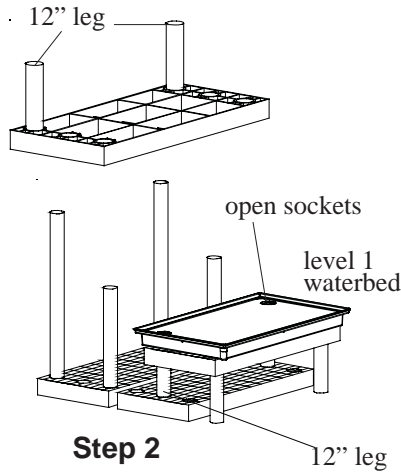
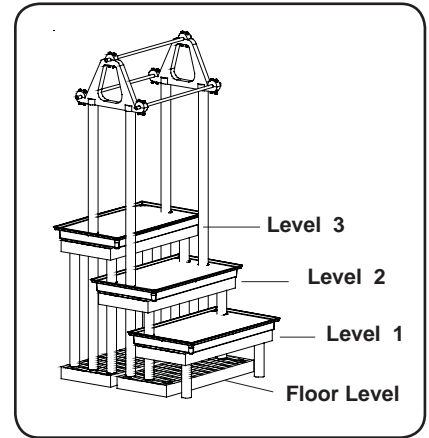

### Step 2

#### Level 1

- A. Invert first level panel and insert (2) 12" legs in outside sockets as shown. Next, position the Level 1 Panel on 12" legs overhanging outside edge as shown.
- B. Position waterbed with 2 outside open holes on level 1. Make sure sockets are facing to the back.

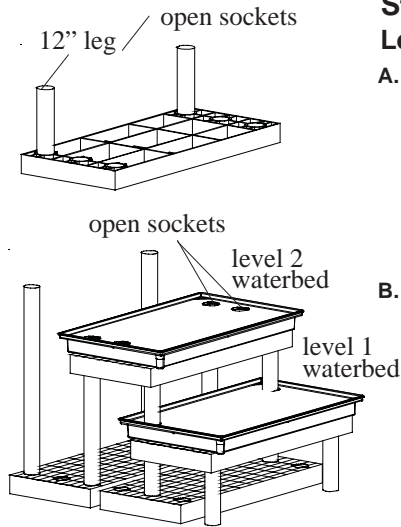

### Step 3

#### Level 2

- A. Invert Level 2 panel and place (2) 12" legs in outside sockets. Next, Position panel on 24" legs while placing 12" legs on the Level 1 panel. Push panel down so that the 24" legs are seated in the sockets.
- B. Position waterbed with 4 outside/center open hole sockets on second level. Make sure sockets are facing to the back.

### Step 4

#### Level 3

- A. Invert Level 3 panel and place (2) 12" legs in outside corners.
- B. Position panel on 36" legs while placing 12" legs into the Level 2 waterbed open holes. Push panel down so that the 36" legs are seated in the sockets.
- C. Next, position Level 3 waterbed (open holes) on level 3 panel with center holes in the center as shown.

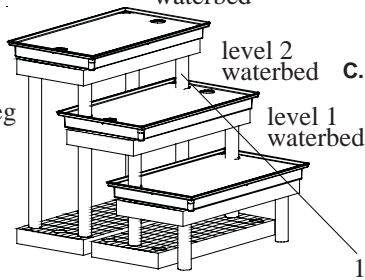
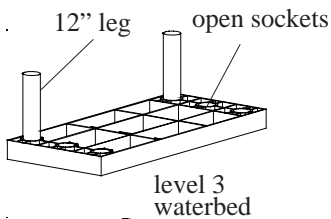

Oiling the sockets will make this step easier.

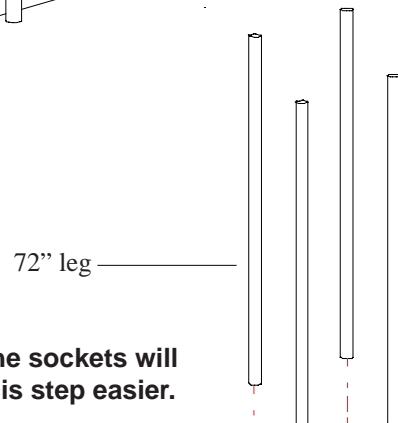

### Step 5

#### Plant Hanger

Insert 72" legs into center open hole sockets of Levels 3 and 2. Slide legs all the way through open hole sockets in waterbeds, panels and floor panels. (Make sure to push legs all the way down to the floor).

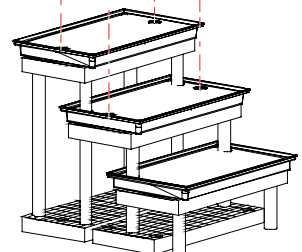

# ASSEMBLY INSTRUCTIONS

## SM367203WWB

Page 2

Oil All Sockets  
Before Assembly

**Components:**  
Plant Hanger Tops: 2  
Plant Hanger Collars: 6  
Plant Hanger Poles: 3  
Bolts: 12  
Wingnuts: 12

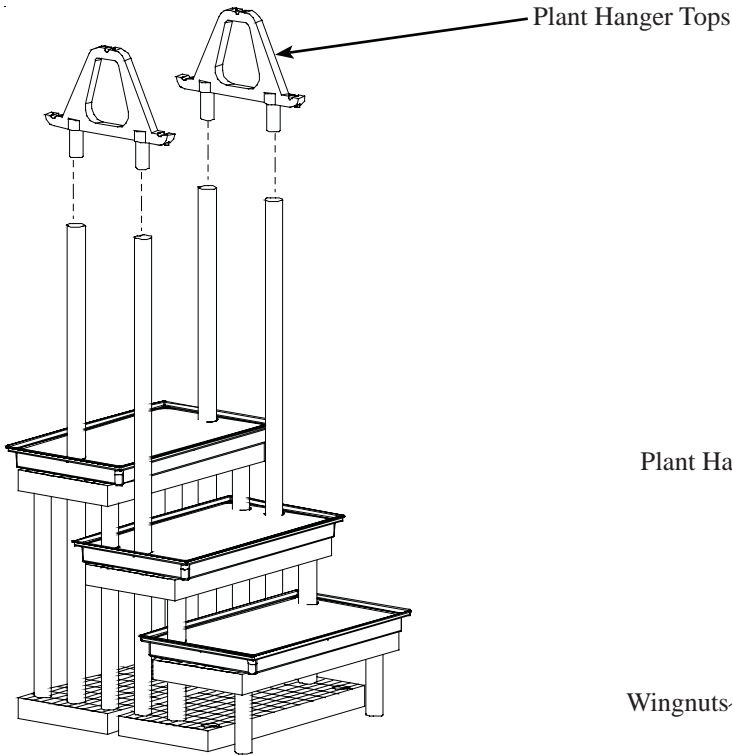

### Step 6 Plant Hanger

Insert Plant hanger tops in 72" legs as shown.

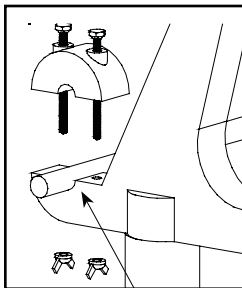

Groove for  
Plant Hanger  
Poles

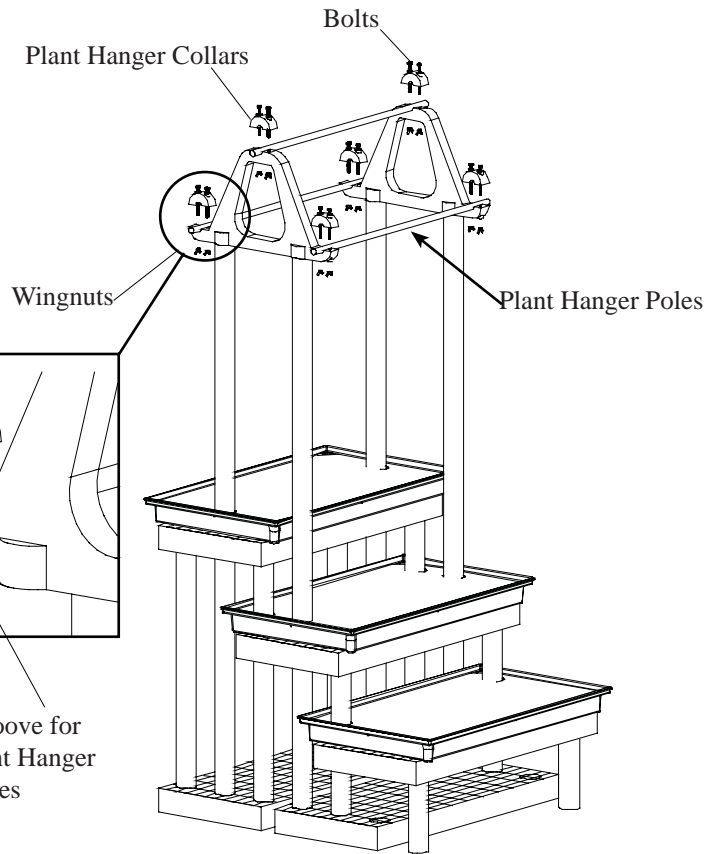

### Step 7 Plant Hanger

Next, place 36" plant hanger poles into small groove in plant hanger top. Place plant hanger collars over poles and fasten down with bolts and wingnuts.